

# Switch Mode Power Supply Multi-Layer Capacitors

High Rel. Space Level NPO(BP) & X7R (BQ, BR & BX) – 50 Vdc to 500 Vdc



**CalRamic Technologies LLC** manufactures a series of highly reliable, military / commercial grade, leaded SMPS ceramic capacitors in accordance with MIL-PRF-49470 and 87106 equivalents that feature large capacitance values and are designed for use in a variety of applications including input and output filters for switch mode power supplies, DC to DC converters, decoupling, snubbers, energy storage and high capacitance discharge circuits.

Available with ultra-stable Class I, NPO and stable Class II, X7R (BQ, BR & BX) dielectric materials, these designs exhibit inherently low Equivalent Series Resistance (ESR) and Equivalent Series Inductance (ESL) characteristics, making them the preferred choice versus higher loss Aluminum and Tantalum electrolytic capacitors at operational frequencies up to 1MHz.

# B

## Lead Configurations

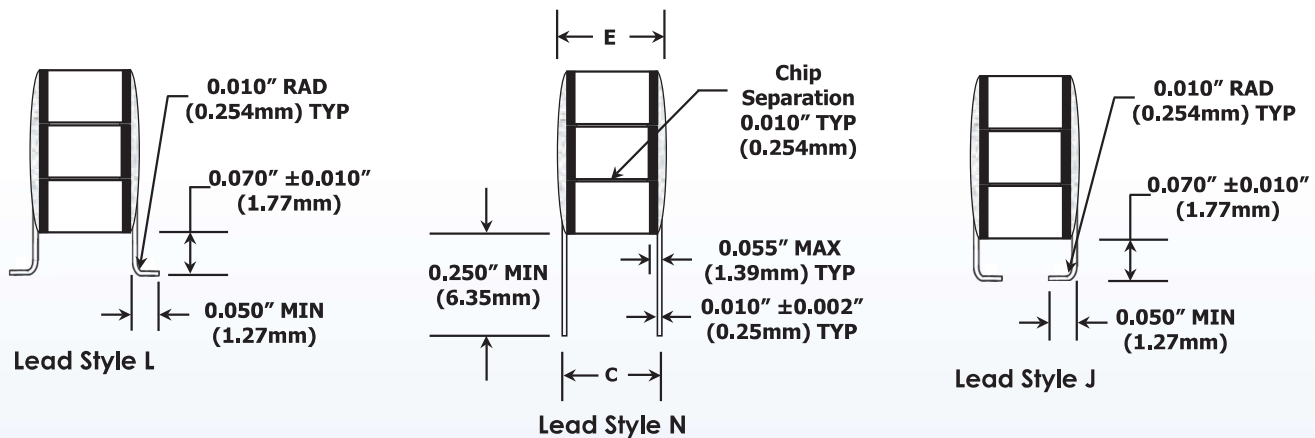

## Mechanical Dimensions

Case Code	A Max	B Max	C ± 0.025 (0.63mm)	D Min / Max	E Max	Number of Leads Per Side
3	Ref. Table 1	0.715" (18.16mm)	0.450" (11.43mm)	0.950" - 1.075" (24.13mm - 27.3mm)	0.500" (12.7mm)	10
4	Ref. Table 1	0.545" (13.14mm)	0.400" (10.16mm)	0.350" - 0.425" (8.89mm - 10.79mm)	0.440" (11.17mm)	4
5	Ref. Table 1	0.545" (13.14mm)	0.250" (6.35mm)	0.224" - 0.275" (5.68mm - 6.98mm)	0.300" (7.62mm)	3

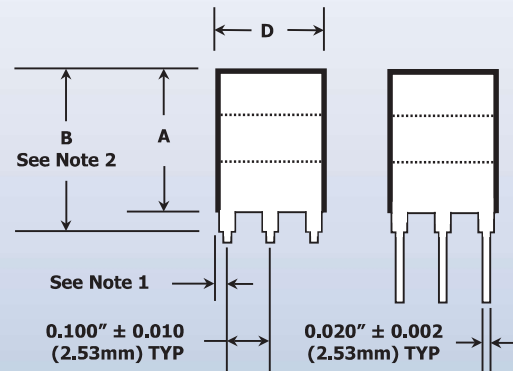

## Notes

- Case Code 3 & 4 @ 0.025" – 0.100" (0.63 – 2.54mm) Case Code 5 @ 0.012" – 0.100" (0.30 – 0.100mm).
- Dimension B MAX = Dimension A + 0.065" (1.65mm).
  - Reference Electrical Characteristics
  - Table 1 for actual "A" height dimension.
  - Tin – Lead plating utilized for all lead configurations.
  - Vertical stack available upon request – Contact Factory.

# Switch Mode Power Supply Multi-Layer Capacitors

High Rel. Space Level NPO(BP) & X7R (BQ, BR & BX) – 50 Vdc to 500 Vdc

## Performance Characteristics

Specification	Dielectric Type (EIA Designation)				
	NPO (BP)	X7R [BQ]	X7R [BR]	X7R [BX]	
Material Classification	Type I, Ultra Stable		Type II, Stable		
Coefficient of Thermal Expansion	9 x 10 <sup>-6</sup> / °C		11 x 10 <sup>-6</sup> / °C		
Density	67 g / in <sup>3</sup>				
Operating Temperature Range	-55 to +125°C				
Aging Rate	0		-2% Max per decade hour		
Temperature Coefficient	0 ±30 PPM / °C		±15%		
Voltage - Temperature Coefficient	0 PPM / °C ±30 PPM / °C		+15 / -50%	+15 / -40%	+15 / -25%
Capacitance Range	0.010 to 2.2 µF		0.150 to 5.6 µF	0.470 to 12 µF	0.680 to 47 µF
Voltage Range	50 VDC to 500 VDC				
Insulation Resistance @ +25°C	100,000 MΩ or 1000 MΩ - µF, W/E is less				
Insulation Resistance @ +125°C	10,000 MΩ or 100 MΩ - µF, W/E is less				
Dissipation Factor	0.15% Max @ 1 kHz & 1 VRMS Max		2.5% Max @ 1 kHz & 1 VRMS Max		
DWV	2.5 X WVDC @ 50, 100 & 200 VDC / 1.5 X WVDC @ 500 VDC				

## Notes

- Group A screening available to MIL-PRF-49470. [Voltage conditioning performed at 2.0 x WVDC for product rated at > 500 VDC & 1.2 x WVDC for product rated at ≤ 500 VDC].
- Voltage – Temperature Coefficient limits define the allowable capacitance change as a percentage of the +25°C measured value, across the temperature range of -55 to +125°C, while under bias.
- Special testing including Ultrasound (C-SAM). Contact factory for more information.
- Custom voltages, package sizes and capacitance values are available. Contact factory for more information.
- X7R dielectrics are not intended for AC line filtering applications.
- Large ceramic capacitors, even leaded devices are susceptible to damage when exposed to thermal and / or mechanical shock. Refer to Technical Bulletin AN112 for handling and installation recommendations.
- Calramic Technologies recommends the use of a lower profile capacitor design for those applications where high vibration or mechanical shock may be a concern.
- The use of a Tin – Lead alloy with a minimum of 3% lead content per mass, has proven to be an effective means of inhibiting reliability concerns related to tin whisker growth.

## Part Number / Ordering Information

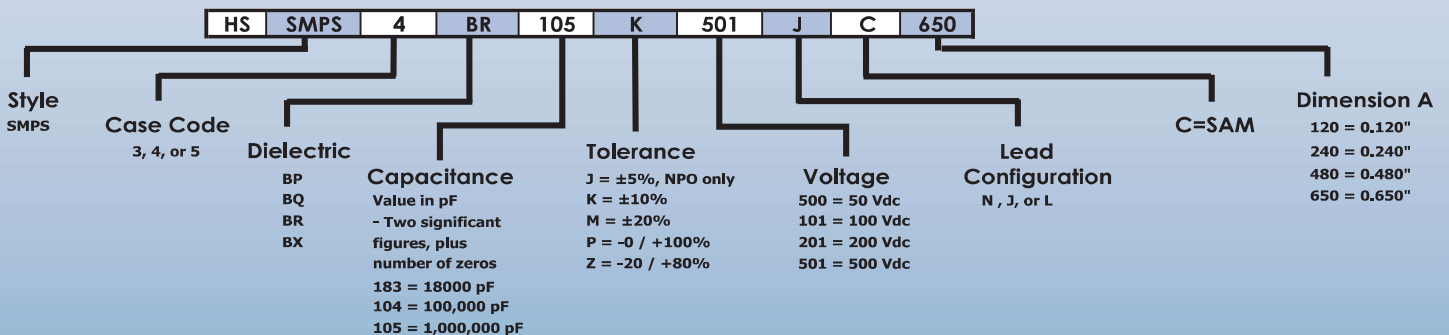

Note: Ultrasound (C-SAM) is not included unless designated in part number.

# Switch Mode Power Supply Multi-Layer Capacitors

High Rel. Space Level NPO(BP) & X7R (BQ, BR & BX) – 50 Vdc to 500 Vdc



## Electrical / Mechanical Characteristics

NPO (BP) Dielectric								
Capacitance (µF)	Case Code (in)	Max "A" Dim (in)	Case Code (in)	Max "A" Dim (in)	Case Code (in)	Max "A" Dim (in)	Case Code (in)	Max "A" Dim (in)
	50V (BP)		100V (BP)		200V (BP)		500V (BP)	
0.010							5	0.120
0.012							5	0.240
0.015							5	0.240
0.018							5	0.240
0.022					5	0.120	5	0.360
0.027					5	0.240	5	0.360
0.033					5	0.240	4 / 5	0.240 / 0.480
0.039					5	0.240	4 / 5	0.240 / 0.480
0.047			5	0.240	5	0.360	4 / 5	0.240 / 0.650
0.056	5	0.120	5	0.240	5	0.360	4	0.360
0.068	5	0.240	5	0.240	4 / 5	0.120 / 0.480	4	0.360
0.082	5	0.240	5	0.240	4 / 5	0.240 / 0.480	4	0.480
0.10	5	0.240	5	0.360	4 / 5	0.240 / 0.650	4	0.480
0.12	5	0.360	5	0.360	4	0.360	3 / 4	0.240 / 0.650
0.15	5	0.360	4 / 5	0.240 / 0.480	4	0.360	3	0.240
0.18	4 / 5	0.240 / 0.480	4 / 5	0.240 / 0.650	4	0.480	3	0.240
0.22	4 / 5	0.240 / 0.480	4 / 5	0.240 / 0.650	4	0.480	3	0.360
0.27	4 / 5	0.240 / 0.650	4	0.360	3 / 4	0.240 / 0.650	3	0.360
0.33	4	0.360	4	0.480	3	0.240	3	0.480
0.39	4	0.480	4	0.480	3	0.240	3	0.650
0.47	4	0.480	3 / 4	0.240 / 0.650	3	0.360		
0.56	3 / 4	0.240 / 0.650	3 / 4	0.240 / 0.650	3	0.360		
0.68	3	0.240	3	0.240	3	0.480		
0.82	3	0.240	3	0.120	3	0.360		
1.0	3	0.360	3	0.360	3	0.650		
1.2	3	0.360	3	0.480				
1.5	3	0.480	3	0.480				
1.8	3	0.480	3	0.650				
2.2	3	0.650						
2.7								
3.3								
3.9								
4.7								

X7R Dielectric (BQ, BR, BX)								
Capacitance (µF)	Case Code (in)	Max "A" Dim (in)	Case Code (in)	Max "A" Dim (in)	Case Code (in)	Max "A" Dim (in)	Case Code (in)	Max "A" Dim (in)
	50V (BX)		100V (BX)		200V (BR)		500V (BQ)	
0.10								
0.12								
0.15							5	0.120
0.18							5	0.240
0.22							5	0.240
0.27							5	0.240
0.33							5	0.360
0.39							5	0.360
0.47							5	0.240
0.56							5	0.240
0.68							4 / 5	0.240 / 0.480
0.82							4	0.360
1.0	5	0.120	5	0.240	4 / 5	0.120 / 0.480	4	0.360
1.2	5	0.120	5	0.240	4 / 5	0.240 / 0.480	4	0.360
1.5	5	0.240	5	0.360	4 / 5	0.240 / 0.650	4	0.480
1.8	5	0.240	5	0.360	4	0.360	3 / 4	0.240 / 0.650
2.2	5	0.240	5	0.480	4	0.360	3	0.240
2.7	5	0.360	5	0.480	4	0.480	3	0.360
3.3	5	0.360	4 / 5	0.240 / 0.650	4	0.480	3	0.360
3.9	5	0.480	4	0.360	3 / 4	0.240 / 0.650	3	0.360
4.7	4 / 5	0.240 / 0.480	4	0.360	3	0.240	3	0.480
5.6	4 / 5	0.240 / 0.650	4	0.480	3	0.240	3	0.650
6.8	4	0.360	4	0.480	3	0.360		
8.2	4	0.360	4	0.650	3	0.360		
10.0	4	0.480	3	0.240	3	0.480		
12.0	4	0.480	3	0.240	3	0.650		
15.0	3 / 4	0.240 / 0.650	3	0.360				
18.0	3	0.240	3	0.360				
22.0	3	0.360	3	0.480				
27.0	3	0.360	3	0.650				
33.0	3	0.360						
39.0	3	0.480						
47.0	3	0.650						

B

# Switch Mode Power Supply Multi-Layer Capacitors

High Rel. Space Level NPO(BP) & X7R (BQ, BR & BX) – 50 Vdc to 500 Vdc

## Performance Charts (Typical)

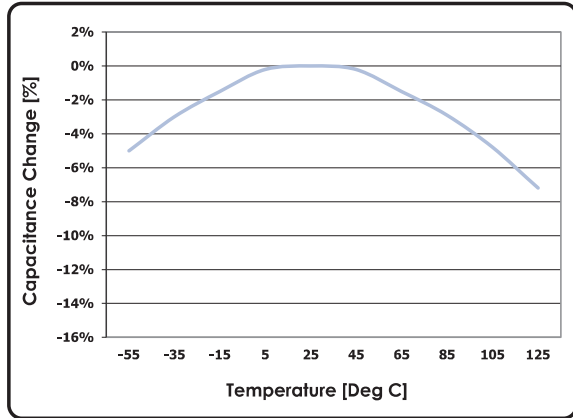

**X7R Temperature Coefficient**

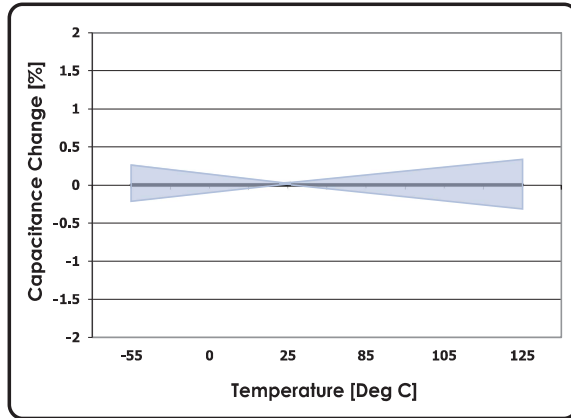

**NPO Temperature Coefficient**

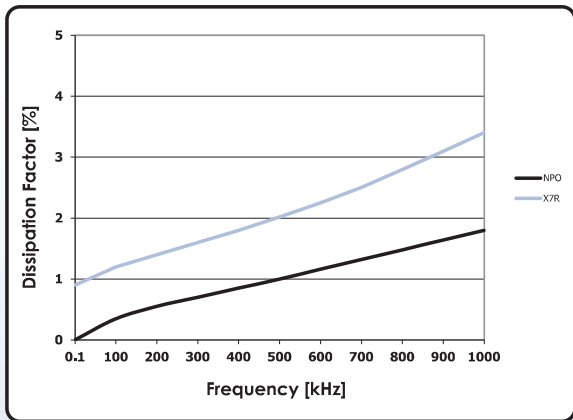

**DF Vs Frequency**

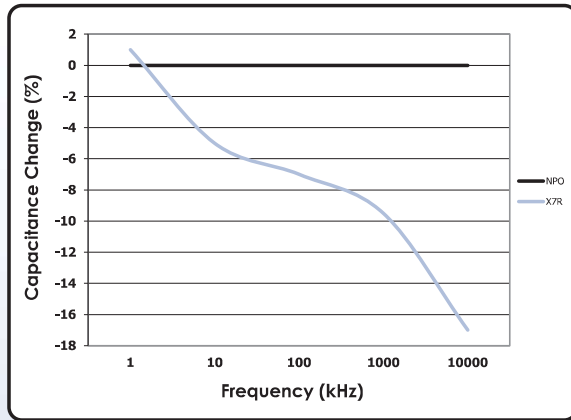

**Capacitance Vs Frequency**

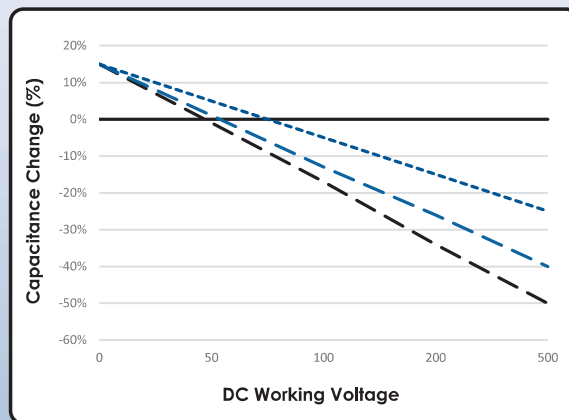

**Voltage Coefficient**

